

Reach truck 1.6 ton



BT reflex

O-series

Indoor/Outdoor

RRE160HR



Reach truck, Indoor/Outdoor

Identification	1.1	Manufacturer			Toyota
	1.2	Model			RRE160HR
	1.3	Drive			Electric
	1.4	Operator type			Seated
	1.5	Load capacity/rated load	Q	kg	1600
	1.6	Load centre	c	mm	600
	1.8	Load distance, centre of support arm wheel to face of fork	x	mm	339
	1.9	Wheelbase	y	mm	1421
	Weight	2.1	Service weight including battery		kg
2.3		Axle load, mast retracted without load, drive/support arm wheel		kg	2260/1552
2.4		Axle load, mast extended with load, drive/support arm wheel		kg	623/4789
2.5		Axle load, mast retracted with load, drive/support arm wheel		kg	1967/3445
Wheels		3.1	Drive/support arm wheel		
	3.2	Wheel size, front		mm	ø 455x160
	3.3	Wheel size, rear		mm	ø 455x160
	3.5	Wheels, number front/rear (x = driven wheels)			1x/2
	3.7	Track width, rear	b ₁₁	mm	1256
Dimensions	4.1	Tilt of fork, forward/backward	α/β	deg	4°/-2° *)
	4.2	Height, mast lowered	h ₁	mm	2957 *)
	4.3	Free lift	h ₂	mm	2403 *)
	4.4	Lift	h ₃	mm	6945 *)
		Lift height	h ₂₃	mm	7000 *)
	4.5	Height, mast extended	h ₄	mm	7610 *)
	4.7	Height of overhead guard (cabin)	h ₆	mm	2330
	4.8	Seat height	h ₇	mm	1268
	4.10	Height support arms	h ₈	mm	478
	4.15	Height, fork lowered	h ₁₃	mm	55
	4.19	Overall length	l ₁	mm	2494
	4.20	Length to face of forks	l ₂	mm	1344
	4.21	Overall width	b ₁	mm	1414
	4.22	Fork dimensions	s/e/l	mm	40/100/1150
	4.23	Fork carriage ISO 2328, class/type A, B			—
	4.24	Fork carriage width	b ₃	mm	819
	4.25	Width over forks	b ₅	mm	252-698
	4.26	Distance between wheel arms/loading surfaces	b ₄	mm	900
	4.28	Reach distance	l ₄	mm	614
	4.31	Ground clearance, with load, below mast	m ₁	mm	136
4.32	Ground clearance, center of wheelbase	m ₂	mm	145	
4.34.1	Aisle width for pallets 1000x1200 crossways	A _{st}	mm	2776	
4.34.2	Aisle width for pallets 800x1200 lengthways	A _{st}	mm	2832	
4.35	Turning radius	W _a	mm	1683	
4.37	Length across support arms	l ₇	mm	1933	
Performance data	5.1	Travel speed, with/without load		km/h	11/11
	5.2	Lift speed, with/without load		m/s	0,36/0,68
	5.2	Lift speed, with/without load (High speed version)		m/s	0,50/0,68
	5.3	Lowering speed, with/without load		m/s	0,55/0,59
	5.4	Reach speed, with/without load		m/s	0,20/0,28
	5.8	Max. gradeability, with/without load ¹⁾		%	8/12,5
	5.9	Acceleration time with/without load (over 10 m)		s	5,8/5,1
5.10	Service brake			Electric	
Electric motor	6.1	Drive motor rating S2 60 min		kW	7,5
	6.2	Lift motor rating S3 15%		kW	11,0
	6.2	Lift motor rating S3 15% (High speed version)		kW	15,0
	6.4	Battery voltage, nominal capacity K _s		V/Ah	48/620
	6.5	Battery weight		kg	875
	6.6	Energy consumption acc to VDI		kWh/h	4,2
	6.7	Turnover output acc VDI 2198		t/h	66
	6.8	Energy consumption at turnover output		kWh/h	3,7
Other	8.1	Type of drive control			Variable AC
	8.4	Sound level at the driver's ear according to EN 12 053		dB(A)	66

1) Measured according to company standard

*) Other alternatives are available

All data are based on table configuration. Other configurations may give other values.

Truck performance and dimensions are nominal and subject to tolerances.

Toyota Material Handling Manufacturing Sweden AB products and specifications are subject to change without notice.

Battery compartment

Dimensions				RRE160HR	
Mast type				Triplex Hi-Lo - A	
	Battery compartment		mm	347	
1.8	Load distance, centre of support arm wheel to face of forks	x	mm	339	
4.20	Length to face of forks	l_2	mm	1344	
4.33	Aisle width for pallets 1000x1200 crossways	A_{st}	mm	2776	
4.34	Aisle width for pallets 800x1200 lengthways	A_{st}	mm	2832	
4.35	Turning radius	W_a	mm	1683	
6.4	Battery voltage, nominal capacity K_5		V/Ah	48/620	
6.5	Battery weight, min.—max.		kg	875/1030	

Mast dimensions

RRE160HR				Triplex Hi-Lo - A						
	Lift height	h_{23}	mm	4900	5400	5700	6300	7000	7250	7500
4.4	Lift	h_3	mm	4845	5345	5645	6245	6945	7195	7445
4.2	Height, mast lowered	h_1	mm	2257	2424	2524	2724	2957	3041	3124
4.3	Free lift	h_2	mm	1703	1871	1971	2171	2403	2487	2571
4.5	Height, mast extended	h_4	mm	5510	6011	6311	6911	7610	7862	8111

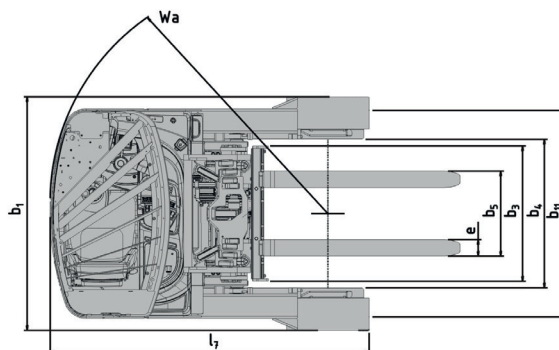
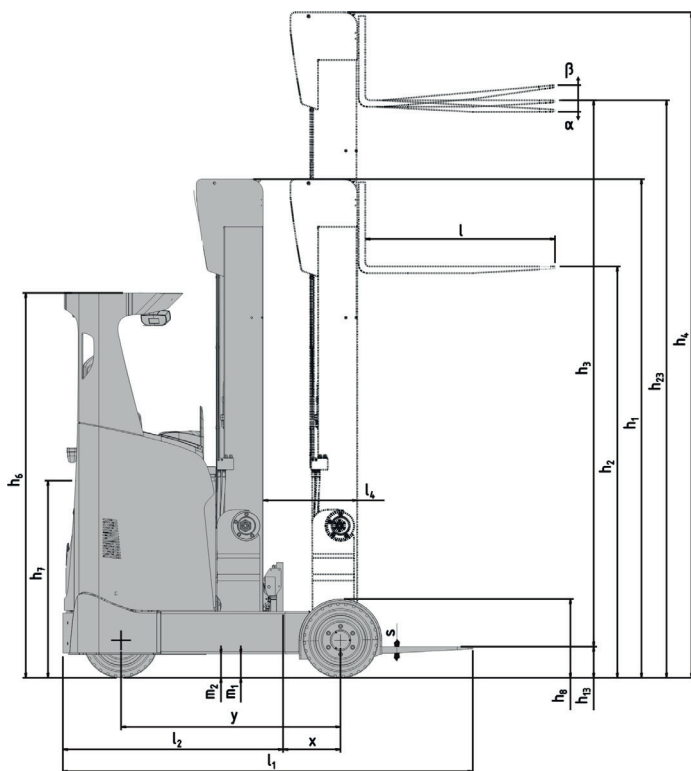

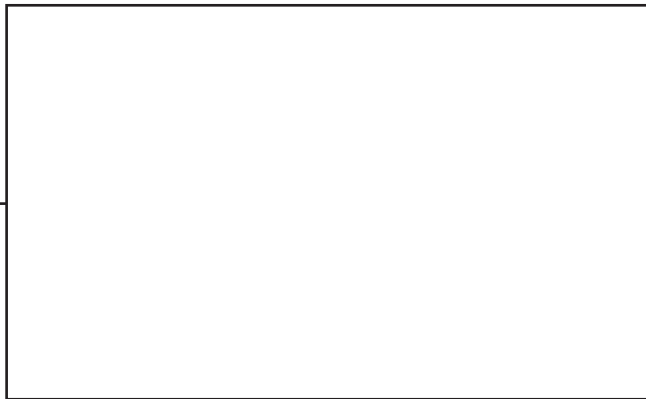

TP-Technical Publications, Sweden — 749997-040, version 4, 2018-01-17

TOYOTA

MATERIAL HANDLING