

Reach truck 1.4 - 2.5 ton



BT reflex

R & E-series

Coldstore

RRE140HC/HEC/
HCC/HECC

RRE160HC/HEC/
HCC/HECC

RRE180HC/HEC/
HCC/HECC

RRE200HC/HEC/
HCC/HECC

RRE250HC/HEC/
HCC/HECC



Reach truck, Coldstore open cabin

Identification	1.1	Manufacturer			Toyota	Toyota	Toyota	Toyota	Toyota
	1.2	Model			RRE140HC/HEC	RRE160HC/HEC	RRE180HC/HEC	RRE200HC/HEC	RRE250HC/HEC
	1.3	Drive			Electric	Electric	Electric	Electric	Electric
	1.4	Operator type			Seated	Seated	Seated	Seated	Seated
	1.5	Load capacity/rated load	Q	kg	1400	1600	1800	2000	2500
	1.6	Load centre	c	mm	600	600	600	600	600
	1.8	Load distance, centre of support arm wheel to face of fork	x	mm	310 *	394 *	373 *	433 *	388 *
	1.9	Wheelbase	y	mm	1311	1395	1455	1515	1575
	Weight	2.1	Service weight including battery		kg	3390	3398	3908	4091
2.3		Axle load, mast retracted without load, drive/support arm wheel		kg	2067/1323	2123/1274	2357/1551	2510/1581	2702/1912
2.4		Axle load, mast extended with load, drive/support arm wheel		kg	667/4123	607/4390	717/4991	764/5327	721/6392
2.5		Axle load, mast retracted with load, drive/support arm wheel		kg	1758/3032	1887/3110	2054/3655	2266/3825	2339/4775
Wheels		3.1	Drive/support arm wheel			Vulkollan®/ Vulkollan®	Vulkollan®/ Vulkollan®	Vulkollan®/ Vulkollan®	Vulkollan®/ Vulkollan®
	3.2	Wheel size, front		mm	ø 350x140	ø 350x140	ø400x160	ø400x160	ø400x160
	3.3	Wheel size, rear		mm	ø 300x106	ø 300x106	ø350x106	ø350x106	ø350x106
	3.5	Wheels, number front/rear (x = driven wheels)			1x/2	1x/2	1x/2	1x/2	1x/2
	3.7	Track width, rear	b ₁₁	mm	1134	1134	1134	1134	1134
Dimensions	4.1	Tilt of fork, forward/backward	α/β	deg	-2°/4° *	-2°/4° *	-2°/4° *	-2°/4° *	-2°/4° *
	4.2	Height, mast lowered	h ₁	mm	2887 *	2887 *	2966 *	2966 *	2936 *
	4.3	Free lift	h ₂	mm	2403 *	2403 *	2459 *	2459 *	2449 *
	4.4	Lift	h ₃	mm	6945 *	6945 *	6945 *	6945 *	6945 *
		Lift height	h ₂₃	mm	7000 *	7000 *	7000 *	7000 *	7000 *
	4.5	Height, mast extended	h ₄	mm	7540 *	7540 *	7548 *	7548 *	7545 *
	4.7	Height of overhead guard (cabin)	h ₆	mm	2198	2198	2261	2261	2261
	4.8	Seat height	h ₇	mm	1136	1136	1198	1198	1198
	4.10	Height support arms	h ₈	mm	268	268	330	330	330
	4.15	Height, fork lowered	h ₁₃	mm	55	55	55	55	55
	4.19	Overall length	l ₁	mm	2413	2413	2494	2494	2599
	4.20	Length to face of forks	l ₂	mm	1263	1263	1344	1344	1449
	4.21	Overall width	b ₁	mm	1270	1270	1270	1270	1270
	4.22	Fork dimensions	s/e/l	mm	40/100/1150 *	40/100/1150 *	40/120/1150 *	40/120/1150 *	45/125/1150 *
	4.23	Fork carriage ISO 2328, class/type A, B			2A	2A	2A	2A	2A
	4.24	Fork carriage width	b ₃	mm	819	819	819	819	819
	4.25	Width over forks	b ₅	mm	252 - 698	252 - 698	272 - 718	272 - 718	277 - 723
	4.26	Distance between wheel arms/loading surfaces	b ₄	mm	900 *	900 *	900 *	900 *	900 *
	4.28	Reach distance	l ₄	mm	506 *	590 *	594 *	654 *	609 *
	4.31	Ground clearance, with load, below mast	m ₁	mm	68	68	68	68	68
4.32	Ground clearance, center of wheelbase ²⁾	m ₂	mm	74	74	74	74	74	
4.34.1	Aisle width for pallets 1000x1200 crossways	A _{st}	mm	2687	2710	2785	2802	2894	
4.34.2	Aisle width for pallets 800x1200 lengthways	A _{st}	mm	2749	2757	2836	2842	2942	
4.35	Turning radius	W _a	mm	1573	1657	1717	1777	1837	
4.37	Length across support arms	l ₇	mm	1744	1828	1913	1973	2033	
Performance data	5.1	Travel speed, with/without load		km/h	10,3/11 ¹⁾	10/11 ¹⁾	11/11	11/11	11/11
	5.1	Travel speed, with/without load (High speed version)		km/h	14/14	14/14	14/14	14/14	14/14
	5.2	Lift speed, with/without load		m/s	0,38/0,68	0,36/0,68	—	—	—
	5.2	Lift speed, with/without load (High speed version)		m/s	0,50/0,68	0,50/0,68	0,46/0,68	0,43/0,68	0,37/0,64
	5.3	Lowering speed, with/without load		m/s	0,55/0,59	0,55/0,59	0,55/0,60	0,55/0,60	0,53/0,58
	5.4	Reach speed, with/without load		m/s	0,20/0,28	0,20/0,28	0,20/0,28	0,20/0,28	0,20/0,28
	5.8	Max. gradeability, with/without load ³⁾		%	10/15	10/15	10/15	10/15	7/12
	5.9	Acceleration time with/without load (over 10 m)		s	5,4/4,9	5,5/4,9	4,9/4,4	5,0/4,5	5,4/4,7
	5.10	Service brake			Electric	Electric	Electric	Electric	Electric
	Electric motor	6.1	Drive motor rating S2 60 min		kW	7,5	7,5	9,0	9,0
6.2		Lift motor rating S3 15%		kW	11,0	11,0	—	—	—
6.2		Lift motor rating S3 15% (High speed version)		kW	15,0	15,0	15,0	15,0	15,0
6.4		Battery voltage, nominal capacity K _s		V/Ah	48/465 *	48/465 *	48/620 *	48/620 *	48/775 *
6.5		Battery weight		kg	685 *	685 *	875 *	875 *	1055 *
6.6		Energy consumption according to VDI cycle		kWh/h	3,4	3,7	3,9	4,7	5,2
6.7		Turnover output		t/h	56	66	76	84	105
6.8		Energy consumption at turnover output		kWh/h	3,2	3,3	3,7	4,2	4,7
Other	8.1	Type of drive control			Variable AC	Variable AC	Variable AC	Variable AC	Variable AC
	8.4	Sound level at the driver's ear according to EN 12 053		dB(A)	66	66	66	66	66

1) 11/11 km/h with support wheel brake.

2) 15 mm under studs.

3) Measured according to company standard.

* Other alternatives are available.

All data are based on table configuration. Other configurations may give other values.

Truck performance and dimensions are nominal and subject to tolerances.

Toyota Material Handling Manufacturing Sweden AB products and specifications are subject to change without notice.

Battery compartment

BT reflex

Dimensions			RRE180HC/HEC						RRE200HC/HEC						RRE250HC/HEC						
Mast type			Triplex Hi-Lo - B			Triplex Hi-Lo - C			Triplex Hi-Lo - B			Triplex Hi-Lo - C			Triplex Hi-Lo - D		Triplex Hi-Lo - C		Triplex Hi-Lo - D		
	Battery compartment	mm	347	419	491	347	419	491	347	419	491	347	419	491	347	419	491	419	491	419	491
1.8	Load distance, centre of support arm wheel to face of forks	x mm	373	301	229	340	268	196	433	361	289	400	328	256	345	273	201	388	316	333	261
4.20	Length to face of forks	l_2 mm	1344	1416	1488	1377	1449	1521	1344	1416	1488	1377	1449	1521	1432	1504	1576	1449	1521	1504	1576
4.33	Aisle width for pallets 1000x1200 crossways	A_{st} mm	2785	2838	2894	2809	2863	2920	2802	2853	2907	2825	2878	2933	2865	2920	2976	2894	2947	2934	2989
4.34	Aisle width for pallets 800x1200 lengthways	A_{st} mm	2836	2901	2967	2865	2931	2998	2842	2906	2972	2871	2936	3002	2921	2987	3053	2942	3007	2992	3058
4.35	Turning radius	W_a mm	1717	1717	1717	1717	1717	1717	1777	1777	1777	1777	1777	1777	1777	1777	1777	1837	1837	1837	1837
6.4	Battery voltage, nominal capacity K_s , Lead-acid	V/Ah	48/620	48/775	48/930	48/620	48/775	48/930	48/620	48/775	48/930	48/620	48/775	48/930	48/620	48/775	48/930	48/775	48/930	48/775	48/930
6.5	Battery weight, min. - max.	kg	875-1030	1055-1235	1250-1440	875-1030	1055-1235	1250-1440	875-1030	1055-1235	1250-1440	875-1030	1055-1235	1250-1440	875-1030	1055-1235	1250-1440	1055-1235	1250-1440	1055-1235	1250-1440

Mast dimensions

RRE180HC/HEC			Triplex Hi-Lo - B											Triplex Hi-Lo - C					
	Lift height	h_{23} mm	4850	5400	5700	6300	7000	7500	8000	8500	9000	9500	10000	10500	11000	11500	12000	12500	13000
4.4	Lift	h_3 mm	4795	5345	5645	6245	6945	7445	7945	8445	8945	9445	9945	10445	10945	11445	11945	12445	12945
4.2	Height, mast lowered	h_1 mm	2249	2432	2532	2732	2966	3132	3299	3466	3632	3799	3966	4132	4299	4463	4630	4797	4963
4.3	Free lift	h_2 mm	1741	1925	2025	2225	2459	2625	2791	2959	3125	3291	3459	3625	3791	3949	4117	4283	4449
4.5	Height, mast extended	h_4 mm	5397	5946	6246	6846	7548	8046	8547	9048	9546	10047	10548	11046	11547	12045	12546	13047	13545

RRE200HC/HEC			Triplex Hi-Lo - B											Triplex Hi-Lo - C				Triplex Hi-Lo - D			
	Lift height	h_{23} mm	4850	5400	5700	6300	7000	7500	8000	8500	9000	9500	10000	10500	11000	11500	12000	12500	13000		
4.4	Lift	h_3 mm	4795	5345	5645	6245	6945	7445	7945	8445	8945	9445	9945	10445	10945	11445	11945	12445	12945		
4.2	Height, mast lowered	h_1 mm	2249	2432	2532	2732	2966	3132	3299	3466	3632	3799	3963	4130	4297	4463	4630	4797	4963		
4.3	Free lift	h_2 mm	1741	1925	2025	2225	2459	2625	2791	2959	3125	3291	3449	3617	3783	3949	4117	4283	4449		
4.5	Height, mast extended	h_4 mm	5397	5946	6246	6846	7548	8046	8547	9048	9546	10047	10545	11046	11547	12045	12546	13047	13545		

RRE250HC/HEC			Triplex Hi-Lo - C											Triplex Hi-Lo - D					
	Lift height	h_{23} mm	4850	5400	5700	6300	7000	7500	8000	8500	9000	9500	10000	10500	11000	11500	12000	12500	13000
4.4	Lift	h_3 mm	4795	5345	5645	6245	6945	7445	7945	8445	8945	9445	9945	10445	10945	11445	11945	12445	12945
4.2	Height, mast lowered	h_1 mm	2247	2430	2530	2730	2936	3130	3297	3463	3630	3797	3963	4130	4297	4463	4630	4797	4963
4.3	Free lift	h_2 mm	1733	1917	2017	2217	2449	2617	2783	2949	3117	3283	3449	3617	3783	3949	4117	4283	4449
4.5	Height, mast extended	h_4 mm	5397	5946	6246	6846	7545	8046	8547	9045	9546	10047	10545	11046	11547	12045	12546	13047	13545

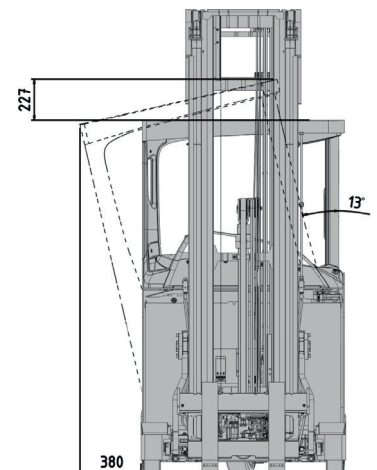
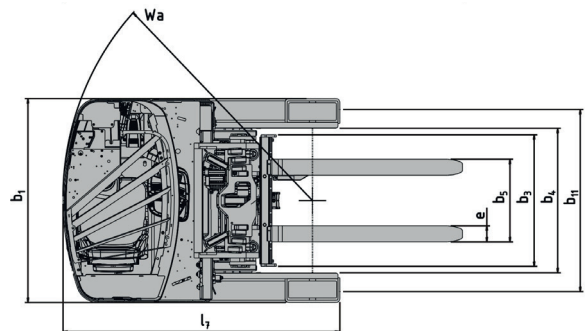
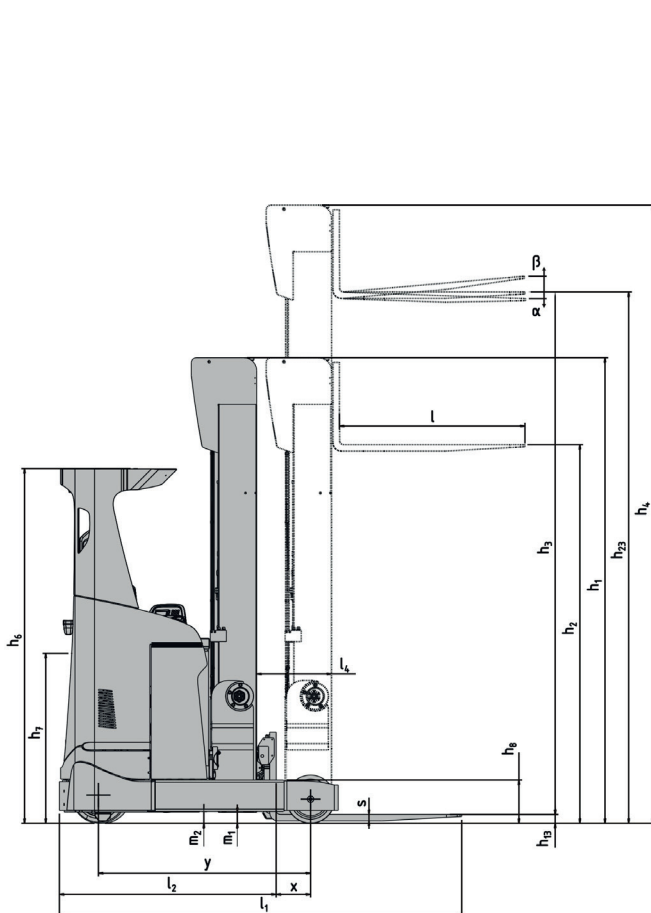

Reach truck, Coldstore closed heated cabin

Identification	1.1	Manufacturer			Toyota	Toyota	Toyota	Toyota	Toyota
	1.2	Model			RRE140HCC/ HECC	RRE160HCC/ HECC	RRE180HCC/ HECC	RRE200HCC/ HECC	RRE250HCC/ HECC
	1.3	Drive			Electric	Electric	Electric	Electric	Electric
	1.4	Operator type			Seated	Seated	Seated	Seated	Seated
	1.5	Load capacity/rated load	Q	kg	1400	1600	1800	2000	2500
	1.6	Load centre	c	mm	600	600	600	600	600
	1.8	Load distance, centre of support arm wheel to face of fork	x	mm	238 *	322 *	373 *	433 *	388 *
	1.9	Wheelbase	y	mm	1311	1395	1455	1515	1575
	Weight	2.1	Service weight including battery		kg	3760	3767	4033	4216
2.3		Axle load, mast retracted without load, drive/support arm wheel		kg	2289/1471	2353/1414	2518/1515	2670/1546	2860/1879
2.4		Axle load, mast extended with load, drive/support arm wheel		kg	967/4193	911/4456	878/4955	924/5292	879/6359
2.5		Axle load, mast retracted with load, drive/support arm wheel		kg	1902/3257	2035/3333	2215/3618	2425/3791	2497/4741
Wheels		3.1	Drive/support arm wheel			Vulkollan®/ Vulkollan®	Vulkollan®/ Vulkollan®	Vulkollan®/ Vulkollan®	Vulkollan®/ Vulkollan®
	3.2	Wheel size, front		mm	ø 350x140	ø 350x140	ø400x160	ø400x160	ø400x160
	3.3	Wheel size, rear		mm	ø 300x106	ø 300x106	ø350x106	ø350x106	ø350x106
	3.5	Wheels, number front/rear (x = driven wheels)			1x/2	1x/2	1x/2	1x/2	1x/2
	3.7	Track width, rear	b ₁₁	mm	1134	1134	1134	1134	1134
Dimensions	4.1	Tilt of fork, forward/backward	α/β	deg	-2°/4° *	-2°/4° *	-2°/4° *	-2°/4° *	-2°/4° *
	4.2	Height, mast lowered	h ₁	mm	2887 *	2887 *	2966 *	2966 *	2936 *
	4.3	Free lift	h ₂	mm	2403 *	2403 *	2459 *	2459 *	2449 *
	4.4	Lift	h ₃	mm	6945 *	6945 *	6945 *	6945 *	6945 *
		Lift height	h ₂₃	mm	7000 *	7000 *	7000 *	7000 *	7000 *
	4.5	Height, mast extended	h ₄	mm	7540 *	7540 *	7548 *	7548 *	7545 *
	4.7	Height of overhead guard (cabin)	h ₆	mm	2200	2200	2263	2263	2263
	4.8	Seat height	h ₇	mm	1136	1136	1198	1198	1198
	4.10	Height support arms	h ₈	mm	268	268	330	330	330
	4.15	Height, fork lowered	h ₁₃	mm	55	55	55	55	55
	4.19	Overall length	l ₁	mm	2548	2548	2557	2557	2662
	4.20	Length to face of forks	l ₂	mm	1398	1398	1407	1407	1512
	4.21	Overall width	b ₁	mm	1270	1270	1270	1270	1270
	4.22	Fork dimensions	s/e/l	mm	40/100/1150 *	40/100/1150 *	40/120/1150 *	40/120/1150 *	45/125/1150 *
	4.23	Fork carriage ISO 2328, class/type A, B			2A	2A	2A	2A	2A
	4.24	Fork carriage width	b ₃	mm	819	819	819	819	819
	4.25	Width over forks	b ₅	mm	252 - 698	252 - 698	272 - 718	272 - 718	277 - 723
	4.26	Distance between wheel arms/loading surfaces	b ₄	mm	900 *	900 *	900 *	900 *	900 *
	4.28	Reach distance	l ₄	mm	434 *	518 *	594 *	654 *	609 *
	4.31	Ground clearance, with load, below mast	m ₁	mm	68	68	68	68	68
	4.32	Ground clearance, center of wheelbase ¹⁾	m ₂	mm	74	74	74	74	74
	4.34.1	Aisle width for pallets 1000x1200 crossways	A _{st}	mm	2802	2825	2848	2865	2957
	4.34.2	Aisle width for pallets 800x1200 lengthways	A _{st}	mm	2877	2885	2899	2905	3005
4.35	Turning radius	W _a	mm	1620	1720	1780	1840	1900	
4.37	Length across support arms	l ₇	mm	1807	1891	1976	2036	2096	
Performance data	5.1	Travel speed, with/without load		km/h	10,3/11 ³⁾	10/11 ³⁾	11/11	11/11	11/11
	5.1	Travel speed, with/without load (High speed version)		km/h	14/14	14/14	14/14	14/14	14/14
	5.2	Lift speed, with/without load		m/s	0,38/0,68	0,36/0,68	—	—	—
	5.2	Lift speed, with/without load (High speed version)		m/s	—	0,50/0,68	0,46/0,68	0,43/0,68	0,37/0,64
	5.3	Lowering speed, with/without load		m/s	0,55/0,59	0,55/0,59	0,55/0,60	0,55/0,60	0,53/0,58
	5.4	Reach speed, with/without load		m/s	0,20/0,28	0,20/0,28	0,20/0,28	0,20/0,28	0,20/0,28
	5.8	Max. gradeability, with/without load ²⁾		%	10/15	10/15	10/15	10/15	7/12
5.10	Service brake			Electric	Electric	Electric	Electric	Electric	
Electric motor	6.1	Drive motor rating S2 60 min		kW	7,5	7,5	9,0	9,0	9,0
	6.2	Lift motor rating S3 15%		kW	11,0	11,0	—	—	—
	6.2	Lift motor rating S3 15% (High speed version)		kW	15,0	15,0	15,0	15,0	15,0
	6.4	Battery voltage, nominal capacity K ₅		V/Ah	48/620 *	48/620 *	48/620 *	48/620 *	48/775 *
	6.5	Battery weight		kg	875 *	875 *	875 *	875 *	1055 *
Other	8.1	Type of drive control			Variable AC	Variable AC	Variable AC	Variable AC	Variable AC

1) 15 mm under studs.

2) Measured according to company standard.

* Other alternatives are available.

All data are based on table configuration. Other configurations may give other values.

Truck performance and dimensions are nominal and subject to tolerances.

Toyota Material Handling Manufacturing Sweden AB products and specifications are subject to change without notice.

Battery compartment

BT reflex

Dimensions				RRE140HCC/HECC		RRE160HCC/HECC		
Mast type				Triplex Hi-Lo - A		Triplex Hi-Lo - A		
	Battery compartment		mm	347	419	347	419	491
1.8	Load distance, centre of support arm wheel to face of forks	x	mm	238 ¹⁾	157	322 ¹⁾	250 ¹⁾	169
4.20	Length to face of forks	l_2	mm	1398 ²⁾	1479	1398 ²⁾	1470 ²⁾	1551
4.33	Aisle width for pallets 1000x1200 crossways	A_{st}	mm	2808	2873	2825	2880	2945
4.34	Aisle width for pallets 800x1200 lengthways	A_{st}	mm	2880	2955	2885	2951	3026
4.35	Turning radius	W_a	mm	1638	1638	1720	1720	1720
6.4	Battery voltage, nominal capacity K_5		V/Ah	48/620	48/775	48/620	48/775	48/930
6.5	Battery weight, min. - max.		kg	875 - 1030	1055 - 1235	875 - 1030	1055 - 1235	1250 - 1440

1) With battery in sleigh - 9 mm

2) With battery in sleigh + 9 mm

Mast dimensions

RRE140/160HCC/HECC			Triplex Hi-Lo - A															
	Lift height	h_{23}	mm	4900	5400	5700	6300	7000	7250	7500	8000	8500	9000	9500	10000	10250	10500	11000
4.4	Lift	h_3	mm	4845	5345	5645	6245	6945	7195	7445	7945	8445	8945	9445	9945	10195	10445	10945
4.2	Height, mast lowered	h_1	mm	2187	2354	2454	2654	2887	2971	3054	3221	3387	3554	3721	3887	3971	4054	4221
4.3	Free lift	h_2	mm	1703	1871	1971	2171	2403	2487	2571	2737	2903	3071	3237	3403	3487	3571	3737
4.5	Height, mast extended	h_4	mm	5440	5941	6241	6841	7540	7792	8041	8542	9040	9541	10042	10540	10791	11041	11542

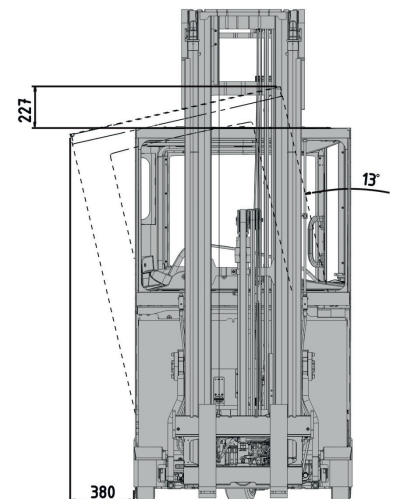
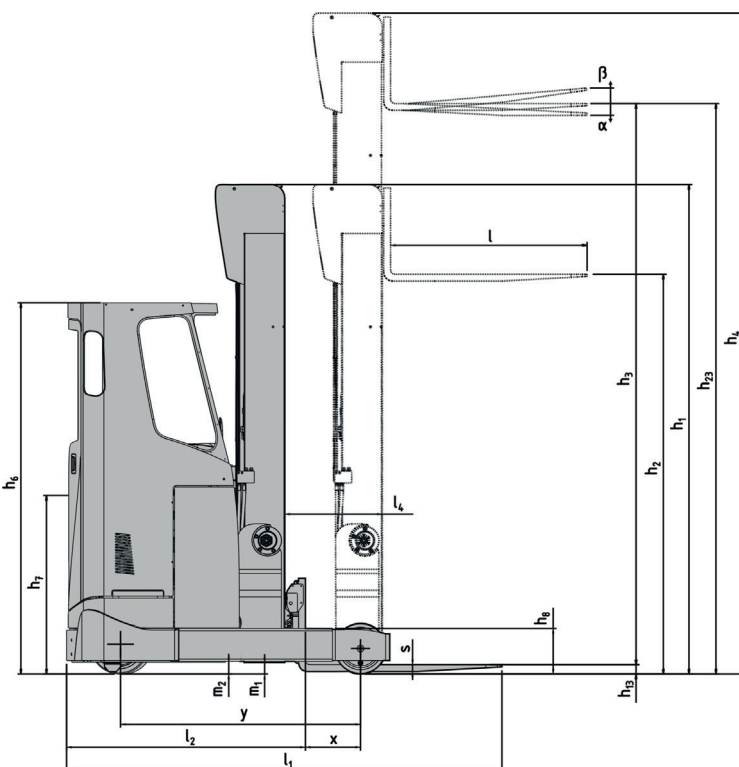
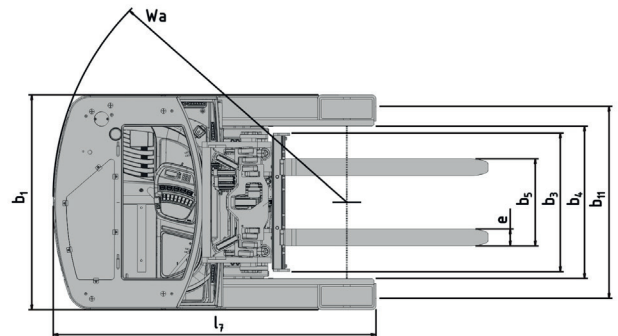

Battery compartment

BT reflex

Dimensions			RRE180HCC/HECC						RRE200HCC/HECC						RRE250HCC/HECC						
Mast type			Triplex Hi-Lo - B			Triplex Hi-Lo - C			Triplex Hi-Lo - B			Triplex Hi-Lo - C			Triplex Hi-Lo - D		Triplex Hi-Lo - C		Triplex Hi-Lo - D		
1.8	Battery compartment	mm	347	419	491	347	419	491	347	419	491	347	419	491	347	419	491	419	491	419	491
	Load distance, centre of support arm wheel to face of forks	x mm	373	301	229	340	268	196	433	361	289	400	328	256	345	273	201	388	316	333	261
4.20	Length to face of forks	l_2 mm	1344	1416	1488	1377	1449	1521	1344	1416	1488	1377	1449	1521	1432	1504	1576	1449	1521	1504	1576
4.33	Aisle width for pallets 1000x1200 crossways	A_{st} mm	2848	2901	2957	2872	2926	2983	2865	2916	2970	2888	2941	2996	2928	2983	3039	2957	3010	2997	3052
4.34	Aisle width for pallets 800x1200 lengthways	A_{sl} mm	2899	2964	3030	2928	2994	3061	2905	2969	3035	2934	2999	3065	2984	3050	3116	3005	3070	3055	3121
4.35	Turning radius	W_0 mm	1780	1780	1780	1780	1780	1780	1840	1840	1840	1840	1840	1840	1840	1840	1840	1900	1900	1900	1900
6.4	Battery voltage, nominal capacity K_5	V/Ah	48/620	48/775	48/930	48/620	48/775	48/930	48/620	48/775	48/930	48/620	48/775	48/930	48/620	48/775	48/930	48/775	48/930	48/775	48/930
6.5	Battery weight, min. - max.	kg	875-1030	1055-1235	1250-1440	875-1030	1055-1235	1250-1440	875-1030	1055-1235	1250-1440	875-1030	1055-1235	1250-1440	875-1030	1055-1235	1250-1440	1055-1235	1250-1440	1055-1235	1250-1440

Mast dimensions

RRE180HCC/HECC			Triplex Hi-Lo - B									Triplex Hi-Lo - C							
	Lift height	h_{23} mm	4850	5400	5700	6300	7000	7500	8000	8500	9000	9500	10000	10500	11000	11500	12000	12500	13000
4.4	Lift	h_3 mm	4795	5345	5645	6245	6945	7445	7945	8445	8945	9445	9945	10445	10945	11445	11945	12445	12945
4.2	Height, mast lowered	h_1 mm	2249	2432	2532	2732	2966	3132	3299	3466	3632	3799	3966	4132	4299	4463	4630	4797	4963
4.3	Free lift	h_2 mm	1741	1925	2025	2225	2459	2625	2791	2959	3125	3291	3459	3625	3791	3949	4117	4283	4449
4.5	Height, mast extended	h_4 mm	5397	5946	6246	6846	7548	8046	8547	9048	9546	10047	10548	11046	11547	12045	12546	13047	13545

RRE200HCC/HECC			Triplex Hi-Lo - B									Triplex Hi-Lo - C				Triplex Hi-Lo - D			
	Lift height	h_{23} mm	4850	5400	5700	6300	7000	7500	8000	8500	9000	9500	10000	10500	11000	11500	12000	12500	13000
4.4	Lift	h_3 mm	4795	5345	5645	6245	6945	7445	7945	8445	8945	9445	9945	10445	10945	11445	11945	12445	12945
4.2	Height, mast lowered	h_1 mm	2249	2432	2532	2732	2966	3132	3299	3466	3632	3799	3963	4130	4297	4463	4630	4797	4963
4.3	Free lift	h_2 mm	1741	1925	2025	2225	2459	2625	2791	2959	3125	3291	3449	3617	3783	3949	4117	4283	4449
4.5	Height, mast extended	h_4 mm	5397	5946	6246	6846	7548	8046	8547	9048	9546	10047	10545	11046	11547	12045	12546	13047	13545

RRE250HCC/HECC			Triplex Hi-Lo - C									Triplex Hi-Lo - D							
	Lift height	h_{23} mm	4850	5400	5700	6300	7000	7500	8000	8500	9000	9500	10000	10500	11000	11500	12000	12500	13000
4.4	Lift	h_3 mm	4795	5345	5645	6245	6945	7445	7945	8445	8945	9445	9945	10445	10945	11445	11945	12445	12945
4.2	Height, mast lowered	h_1 mm	2247	2430	2530	2730	2936	3130	3297	3463	3630	3797	3963	4130	4297	4463	4630	4797	4963
4.3	Free lift	h_2 mm	1733	1917	2017	2217	2449	2617	2783	2949	3117	3283	3449	3617	3783	3949	4117	4283	4449
4.5	Height, mast extended	h_4 mm	5397	5946	6246	6846	7545	8046	8547	9045	9546	10047	10545	11046	11547	12045	12546	13047	13545

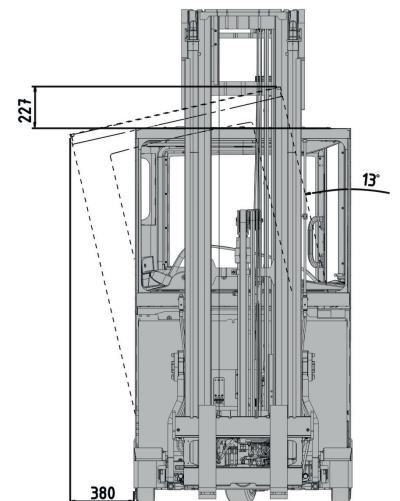
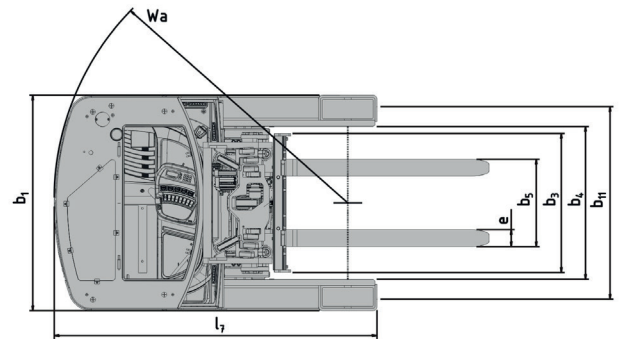
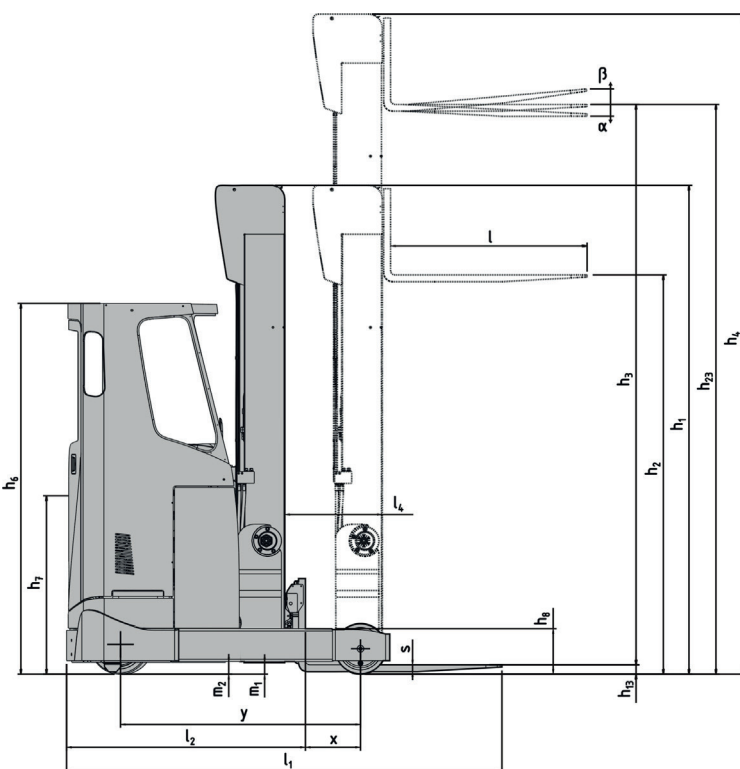



TMHE-Toyota Material Handling Europe — 749996-040, version 8, 2018-11-28

TOYOTA

MATERIAL HANDLING